

# The Fergas Group

## A true global supplier!

The Fergas Group features a network of its own production facilities with co-ordinated quality control and offers the advantage to obtain the Fergas product manufactured to our own universal standard locally at your point of use. We can also supply the local engineering support that you expect to assist you in the design and use of Fergas air movement products.

The Fergas Group consists of:

### Fergas AB, (FAB), Fergas AirBlaster



The Group Headquarters in Linköping, Sweden was established 1949 by our founder Lennart Wallman and is still privately held by the Wallman family. Our facility in Sweden is driven by innovation and top level automation.



### Fergas Asia Pacific Ltd (FAP)



Founded in 2005 as a joint venture between Fergas and Beckett Air Inc., FAP is perfectly located in the south of China in the heart of Asia. From this worldclass facility we serve our customers in the Asia-Pacific region.



### Fergas South Europe (FSE)



Born from the acquisition of Emmevi in Misinto/Italy, FSE is the platform for the further development of the Fergas Group in the Southern European market.



### Beckett Air Inc (BAI)



Was founded in 1988 as a joint venture between RW Beckett Corp. and Fergas AB. It is based in North Ridgeville Ohio and has achieved a dominant market position in North America.

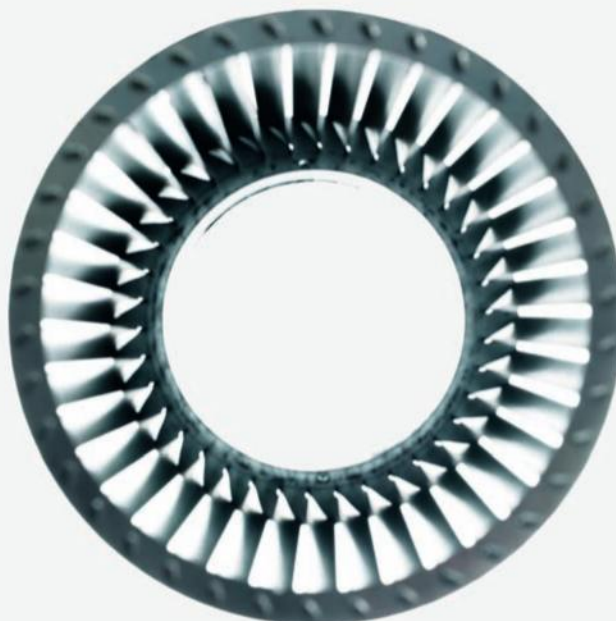

Surf our Web Site  
for more details



“Your global partner in air moving solutions!”



[www.fergas.com](http://www.fergas.com)

Experts in Moving Air - Everywhere!

**BRYTEC**  
Our service, your profit!



Experts in moving air



FERGAS AB

### Crossflow Blowers

- Lengths from 60 to 605 mm
- Single and double version
- AC and DC motor
- Airflows upto 500 m<sup>3</sup>/h
- Various housing design options



30 mm Ø

### EC motor Crossflow Blowers

- 50% lower energy consumption than traditional AC motor
- Lengths from 120 to 420 mm
- Single and double version
- 220 - 240 V or 12/24 V DC
- Available with 0-10V speed control



45/60 mm Ø

### Blower Wheels

- Fergas unique key rivet assembly
- Single and double inlet
- Galvanized steel or aluminium
- With hub or external rotor motor adaptable



67 to 224 mm Ø



45 mm Ø

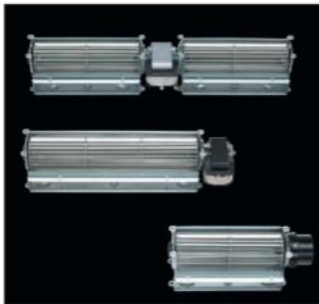

60 mm Ø

### Fume Extraction Fans

- H class insulation motor
- 230V - 50Hz
- Air Flow: 185 m<sup>3</sup>/h
- Working position: horizontal / vertical



150 mm Ø impeller

### Backward Inclined Wheels

- For 92 mm external rotor
- Can be adapted for hub assembly
- Various widths
- Galvanized steel as standard



180/190/225/250/280 mm Ø



65 mm Ø



80 mm Ø

### Oven Fans

- 150 mm Ø impeller
- 230 V - 50/60 Hz
- Aluminium or stainless steel blades
- 6 and 7 blade impellers



150 mm Ø impeller

### Centrifugal Fans

- Single and double inlet version
- 50 mm to 105 mm Ø Impeller
- Air Flow: 20 to 220 m<sup>3</sup>/h (440 m<sup>3</sup>/h for double version)
- 230V - 50/60 Hz



Centrifugal Fans

### Large Crossflow Wheels

- Lengths from 215 mm to 800 mm
- Material options include aluminum and steel
- Wheels can be e-coated for extra protection
- Design and application support available



100/105/110/115/120/125 mm Ø

### Axial Fans

- High airflow
- Low sound level
- Reduced overall dimensions
- Overmolded coils



96/130/154 mm Ø impeller

### AirBlaster

- Brushless 12 or 24V DC motor
- Patented for ventilation of vehicle seats
- High pressure
- Total height: 25 mm
- Advanced speed control options such as PWM or LINBUS

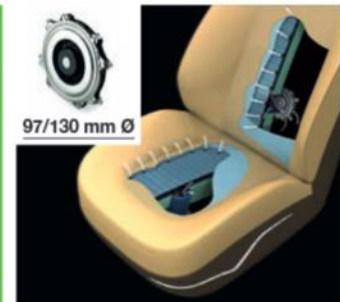

97/130 mm Ø

Climaseat patented technology